

Combination Louver/Damper Concealed Actuator

Application and Design

EACC-601 is a combination louver/damper designed to protect air intake and exhaust openings in building exterior walls that, at times, require tight air shut off. Design incorporates a drainable head member, drainable stationary blades, operable blades and a concealed actuator within the louver sill. When the operable blades are open, airflow is permitted through the louver, when the blades are closed, a tight seal is created to prevent the passage of air.

Standard Construction

- Frame** Heavy gauge extruded 6063-T5 aluminum, 6 in. x 0.125 in. nominal wall thickness
- Blades** Stationary blade: drainable design, heavy gauge extruded 6063-T5 aluminum, 0.081 in. nominal wall thickness, positioned at 45° angles on approximately 6 in. centers
Operable blade: heavy gauge extruded 6063-T5 aluminum, 0.081 nominal wall thickness
- Seals** Dual-durometer extruded vinyl blade seals
Compressible stainless steel jamb seals
- Temperature Restrictions** . . . (-20° F) - (+180° F)
- Linkage** Side linkage out of airstream (concealed in frame)
- Bearings** Synthetic sleeve type
- Axles** ½ in. dia. zinc plated steel
- Actuator** Invensys MA series, 2 positioned spring return
- Construction** . . . Mechanically fastened
- Birdscreen** ¾ in. x 0.051 in. flattened expanded aluminum in removable frame, inside mount (rear)
- Finish** Mill
- Minimum Size** . . 18 in. W x 30 in. H
- Maximum Single Section Size** . . . 60 in. W or 96 in. H

Options (at additional cost)

- A variety of bird and insect screens
- Extended sill
- Filter rack
- Flanged frame
- Hinged frame
- Security bars
- A variety of architectural finishes including:
 - Clear anodize
 - Integral color anodize
 - Baked enamel paint
 - Kynar paint

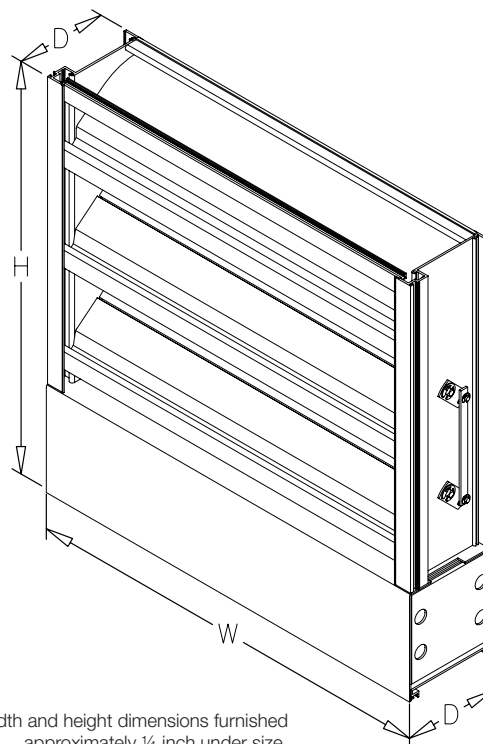
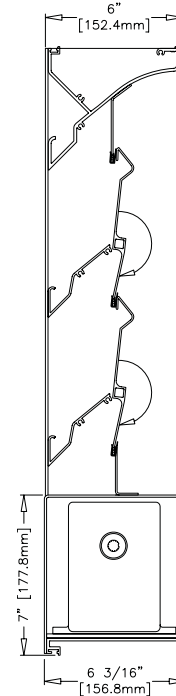

*Width and height dimensions furnished approximately ¼ inch under size.

PERFORMANCE DATA

EACC-601

Combination Louver/Damper
Extruded Aluminum

Free Area Chart (Sq. ft.)

Louver Height Inches	Louver Width in Inches														
	18	21	24	27	30	33	36	39	42	45	48	51	54	57	57
30	0.95	1.13	1.32	1.50	1.68	1.87	2.05	2.24	2.42	2.60	2.79	2.97	3.16	3.34	3.52
33	0.95	1.13	1.32	1.50	1.68	1.87	2.05	2.24	2.42	2.60	2.79	2.97	3.16	3.34	3.52
39	1.31	1.60	1.85	2.11	2.37	2.63	2.89	3.15	3.42	3.67	3.93	4.18	4.44	4.70	4.96
42	1.72	2.06	2.39	2.73	3.06	3.39	3.73	4.06	4.39	4.73	5.06	5.40	5.73	6.06	6.40
48	2.11	2.52	2.93	3.34	3.75	4.16	4.56	4.97	5.38	5.79	6.20	6.61	7.02	7.43	7.84
51	2.11	2.52	2.93	3.34	3.75	4.16	4.56	4.97	5.38	5.79	6.20	6.61	7.02	7.43	7.84
57	2.50	2.98	3.47	3.95	4.43	4.92	5.40	5.89	6.37	6.85	7.34	7.82	8.31	8.79	9.27
60	2.89	2.45	4.00	4.56	5.12	5.68	6.24	6.80	7.36	7.92	8.48	9.03	9.59	10.15	10.71
66	3.27	3.91	4.54	5.18	5.81	6.44	7.08	7.71	8.34	8.98	9.61	10.25	10.88	11.51	12.15
69	3.27	3.91	4.54	5.18	5.81	6.44	7.08	7.71	8.34	8.98	9.61	10.25	10.88	11.51	12.15
75	3.66	4.37	5.08	5.79	6.50	7.21	7.91	8.62	9.33	10.01	10.75	11.46	12.17	12.88	13.59
78	3.66	4.37	5.08	5.79	6.50	7.21	7.91	8.62	9.33	10.01	10.75	11.46	12.17	12.88	13.59
84	4.05	4.83	5.62	6.40	7.18	7.97	8.75	9.54	10.32	11.10	11.89	12.67	13.46	14.24	15.02
87	4.44	5.30	6.15	7.01	7.87	8.73	9.59	10.45	11.31	12.17	13.03	13.88	14.74	15.60	16.46
93	4.82	5.76	6.69	7.63	8.56	9.49	10.43	11.36	12.29	13.23	14.16	15.10	16.03	16.96	17.90
96	4.82	5.76	6.69	7.63	8.56	9.49	10.43	11.36	12.29	13.23	14.16	15.10	16.03	16.96	17.90

Air Leakage (with damper section closed) Test size 48 in. x 48 in.

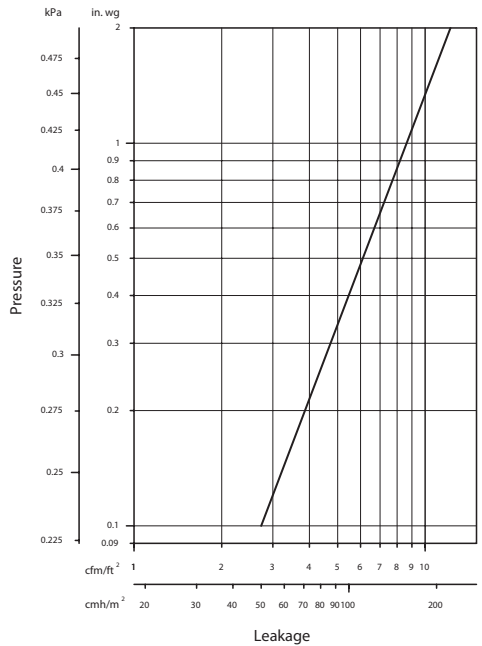

Airflow Resistance (Standard Air - .075 lb/ft³)

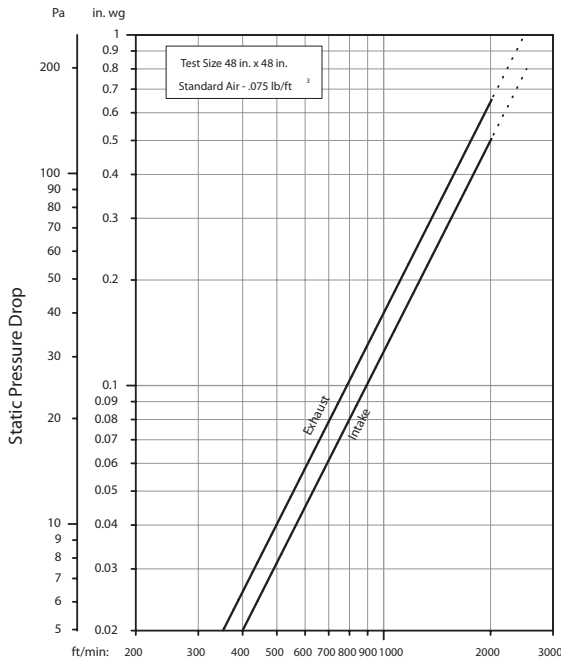

Model EACC-601 resistance to airflow (pressure drop) varies depending on louver application (air intake or air exhaust). Free area velocities (shown) are higher than average velocity through the overall louver size. See louver selection information.

Water Penetration (Standard Air - .075 lb/ft³)

Test size 48 in. x 48 in. Test duration of 15 min.

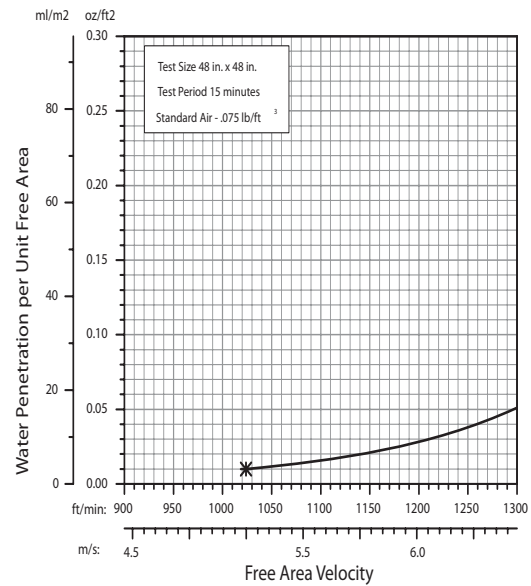

The AMCA Water Penetration Test provides a method for comparing various louver models and designs as to their efficiency in resisting the penetration of rainfall under specific laboratory test conditions. The beginning point of water penetration is defined as that velocity where the water penetration curve projects through .01 oz. of water (penetration) per sq. ft. of louver free area. ***The beginning point of water penetration for Model EACC-601 is 1020 fpm free area velocity.** These performance ratings do not guarantee a louver to be weatherproof or stormproof and should be used in combination with other factors including good engineering judgement in selecting louvers.



INSTALLATION DETAILS

EACC-601

Maximum Size and Installation Information

Combination Louver/Damper
Extruded Aluminum

The maximum single section size for the EACC-601 is 60 in. W or 96 in. H. Larger openings require field assembly of multiple louver panels to make up the overall opening size. Individual louver panels are designed to withstand a 25 PSF wind-load (please consult Greenheck if the louvers must withstand higher wind-loads). Structural reinforcing members may be required to adequately support and install multiple louver panels within a large opening. Structural reinforcing members along with any associated installation hardware is not provided by Greenheck unless indicated otherwise by Greenheck. Additional information on louver installation may be found in AMCA Publication #501, Louver Application Manual.

SINGLE SECTION

MULTIPLE SECTION W/ MULLION

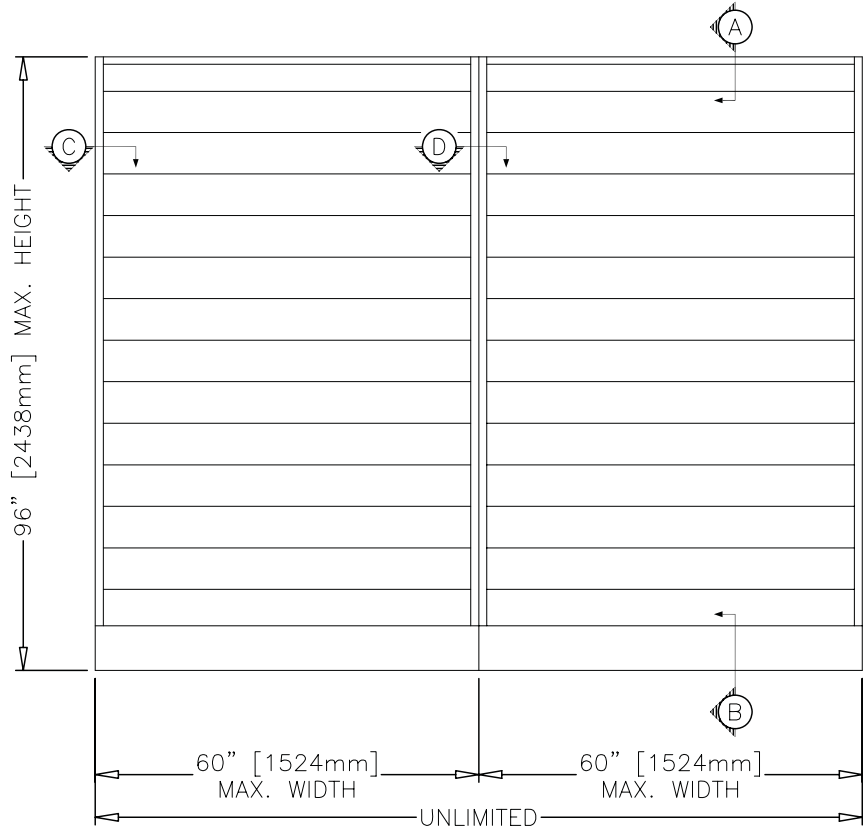
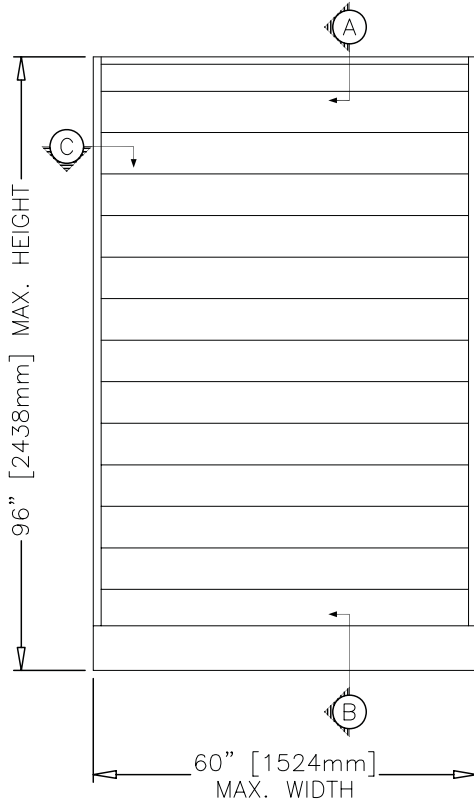

Minimum Single Section Size

18 in. W x 30 in. H

Maximum Single Section Size

60 in. W or 96 in. H

PRODUCT DETAILS

EACC-601

Combination Louver/Damper
Extruded Aluminum

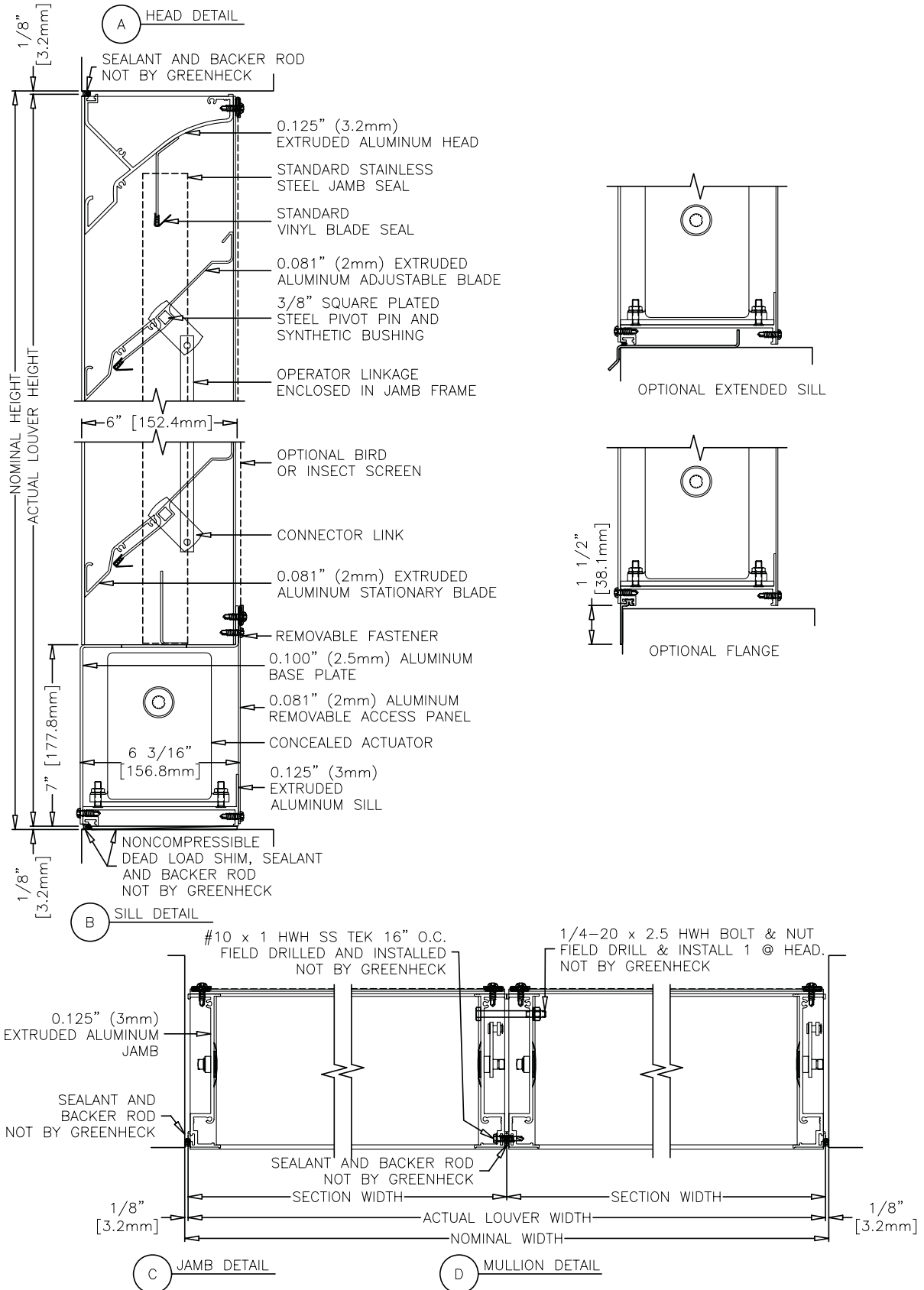

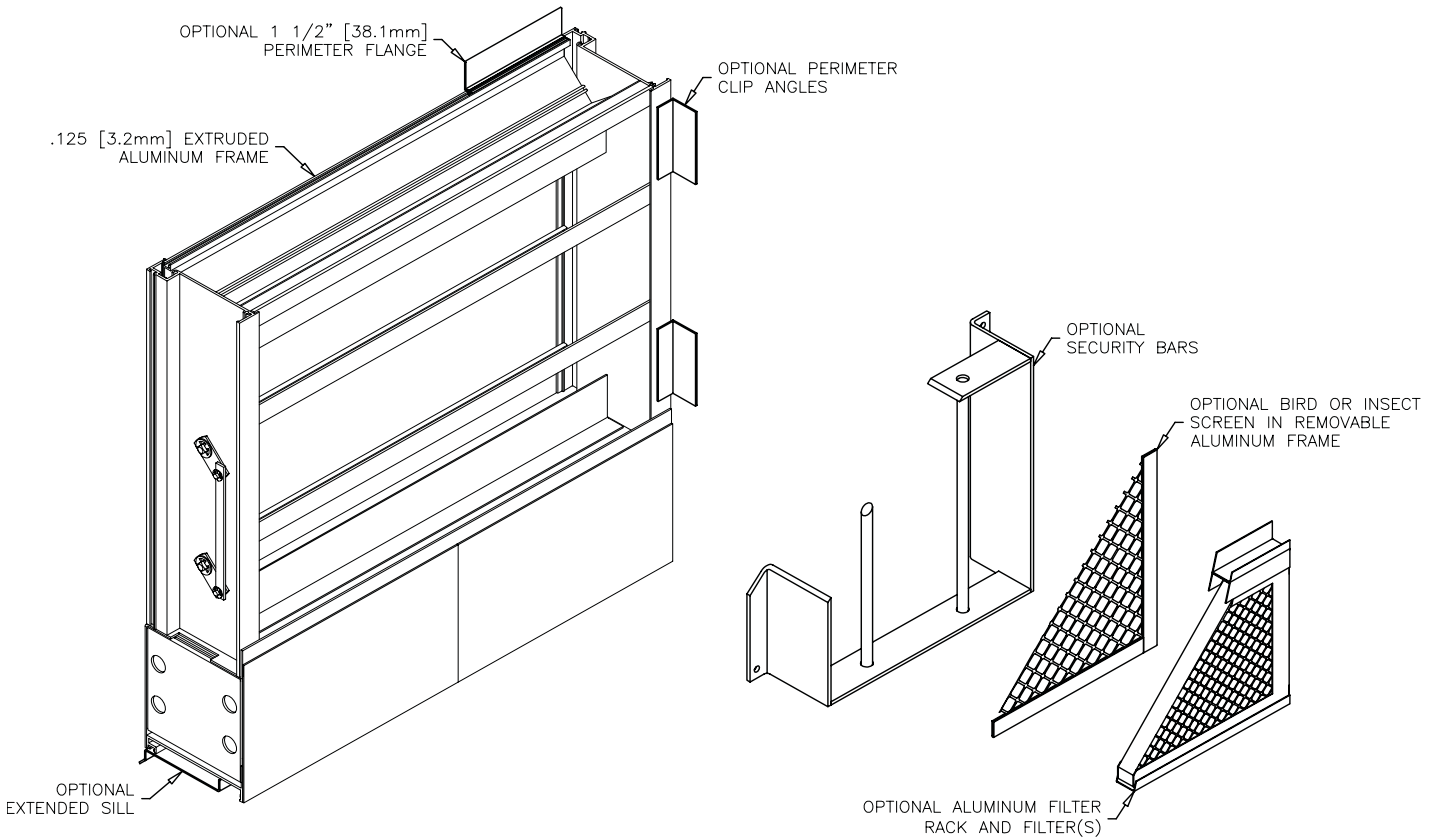

FINISHES

Finish Type	Description/Application	Color Selection	Standard Warranty (Aluminum)
2-coat 70% KYNAR 5000®/HYLAR 5000® AAMA 2605 – Dry film thickness 1.2 mil. (AKA: Duranar®, Fluoropon®, Trinar®, Fluoropolymer, Polyvinylidene Fluoride, PVDF2)	“Best.” The premier finish for extruded aluminum. Tough, long-lasting coating has superior color retention and abrasive properties. Resists chalking, fading, chemical abrasion and weathering.	Standard Colors: Any of the 24 standard colors shown can be furnished in 70% or 50% KYNAR 5000®/HYLAR 5000® or Baked Enamel. 2-Coat Mica: Greenheck offers 9 standard 2-coat Mica colors. Other colors are available. Consult Greenheck for possible extra cost when selecting non-standard colors or special finishes.	10 Years (Consult Greenheck for availability of extended warranty)
2-coat 50% KYNAR 5000®/HYLAR 5000® AAMA 2604 – Dry film thickness 1.2 mil. (AKA: Acroflur®, Acrynar®)	“Better.” Tough, long-lasting coating has excellent color retention and abrasive properties. Resists chalking, fading, chemical abrasion and weathering.		5 Years
Baked Enamel AAMA 2603 – Dry film thickness 0.8 mil. (AKA: Acrabond Plus®, Duracron®)	“Good.” Provides good adhesion and resistance to weathering, corrosion and chemical stain.		1 Year
Integral Color Anodize AA-M10C22A42 (>0.7 mil)	“Two-step” anodizing is produced by following the normal anodizing step with a second, colorfast process.	Light, Medium or Dark Bronze; Champagne; Black	5 years
Clear Anodize 215 R-1 AA-M10C22A41 (>0.7 mil)	Clear, colorless and hard oxide aluminum coating that resists weathering and chemical attack.	Clear	5 years
Clear Anodize 204 R-1 AA-M10C22A31 (0.4-0.7 mil)	Clear, colorless and hard oxide aluminum coating that resists weathering and chemical attack.	Clear	1 Year
Industrial coatings	Greenheck offers a number of industrial coatings such as Hi-Pro Polyester, Epoxy, and Permatector®. Consult a Greenheck Product Specialist for complete color and application information.		Consult Greenheck
Mill	Materials may be supplied in natural aluminum or galvanized steel finish when normal weathering is acceptable and there is no concern for color or color change.		n/a

Finishes meet or exceed AAMA 2605, AAMA 2604, and AAMA 2603 requirements. Please consult www.greenheck.com for complete information on standard and extended paint warranties. Paint finish warranties are not applicable to steel products.

