

Combination Exhaust Louver/Backdraft Damper J Blade

Application and Design

GCE-402 is a combination weather louver and gravity backdraft damper designed to protect air exhaust openings in building exterior wall. Design incorporates a drainable head member, J style stationary louver blades, pressure/gravity operated damper blades and sloped sill to provide maximum resistance to rain and weather. Recommended application is in close proximity (preferably ducted) to an exhaust air fan as pressures required to operate the GCE-402 may exceed pressure differentials available without an adjacent fan. This model is not recommended for barometric relief applications.

Standard Construction

Frame Heavy gauge extruded 6063-T5 aluminum, 4 in. x 0.081 in. nominal wall thickness

Blades Louver blade: J style design, heavy gauge extruded aluminum, 0.081 in. nominal wall thickness, positioned at 45° angles on approximately 4 in. centers
Backdraft damper blade: heavy gauge extruded 6063-T5 aluminum, 0.062 nominal wall thickness

Temperature

Restrictions . . . (-20° F) - (+180° F)

Bearings Synthetic sleeve type

Insect screen . . 3/4 in. x 0.051 in. flattened expanded aluminum in removable frame, inside mount (rear)

Finish Mill

Minimum Size . . 12 in. W x 12 in. H

Maximum Single

Section Size . . . 60 in. W x 120 in. H

Options (at additional cost)

- A variety of bird and insect screens
- A variety of architectural finishes including:
 - Clear anodize
 - Integral color anodize
 - Baked enamel paint
 - Kynar paint
- Extended sill
- Flange frame

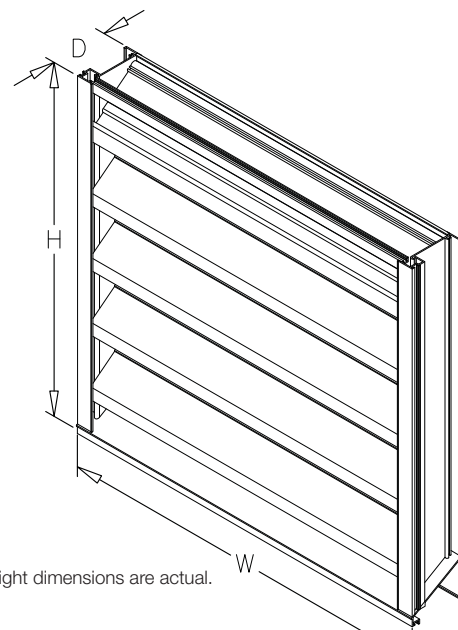
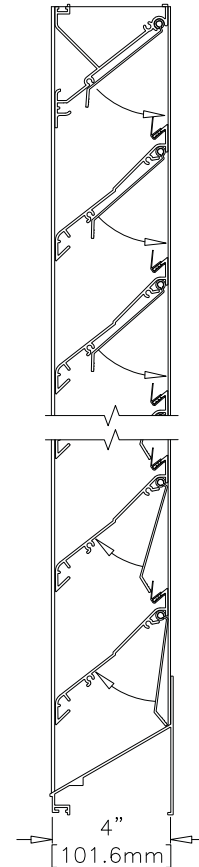

*Width and height dimensions are actual.

AIRFLOW RESISTANCE

(Standard Air - .075 lb/ft³)

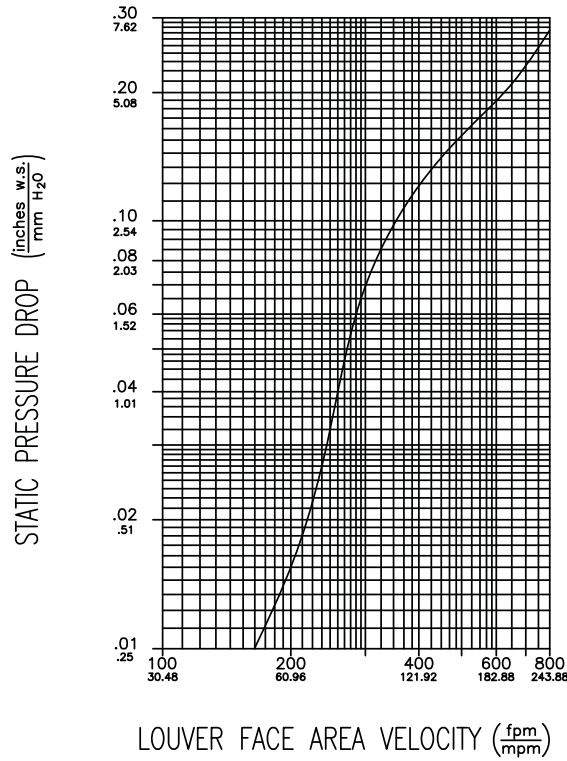

Typical Application

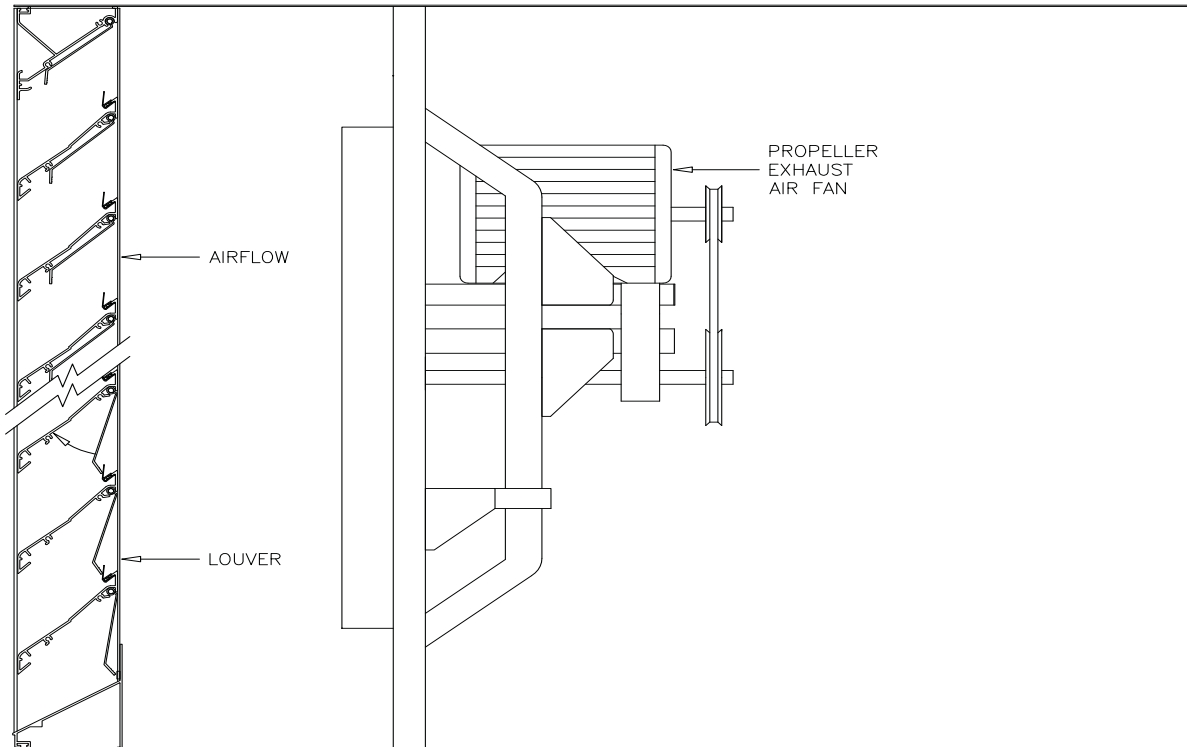

INSTALLATION DETAILS

GCE-402

Maximum Size and Installation Information

Combination Exhaust Louver/Backdraft Damper
Extruded Aluminum

The maximum single section size for the GCE-402 is 60 in. W x 120 in. H. Larger openings require field assembly of multiple louver panels to make up the overall opening size. Individual louver panels are designed to withstand a 25 PSF wind-load (please consult Greenheck if the louvers must withstand higher wind-loads). Structural reinforcing members may be required to adequately support and install multiple louver panels within a large opening. Structural reinforcing members along with any associated installation hardware is not provided by Greenheck unless indicated otherwise by Greenheck. Additional information on louver installation may be found in AMCA Publication #501, Louver Application Manual.

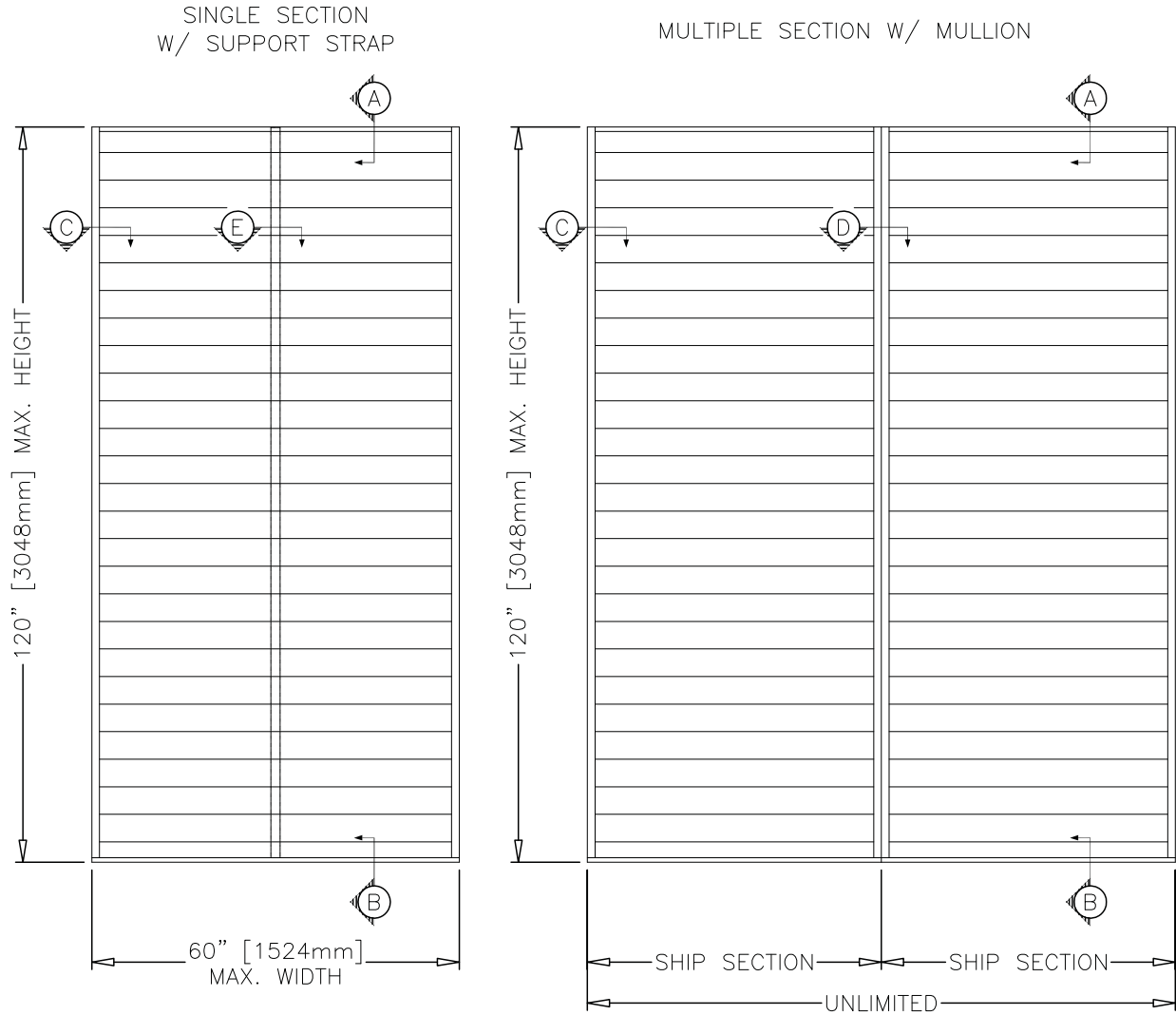

Minimum Single Section Size
6 in. W x 6 in. H

Maximum Single Section Size
60 in. W x 120 in. H

PRODUCT DETAILS

GCE-402

Combination Exhaust Louver/Backdraft Damper
Extruded Aluminum

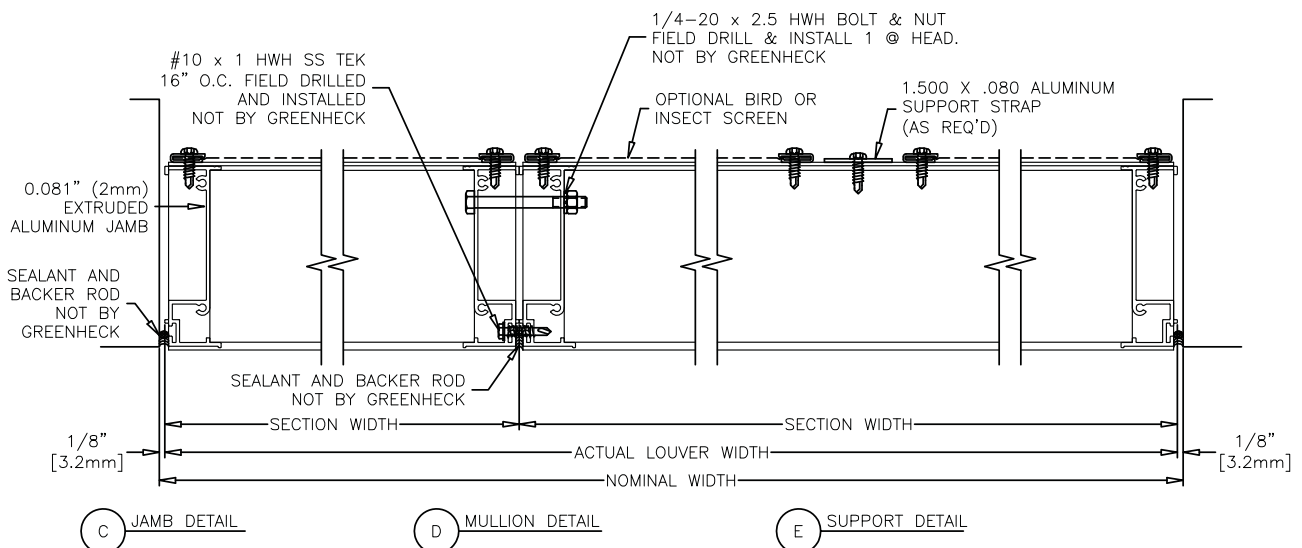
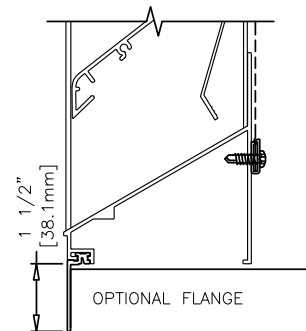
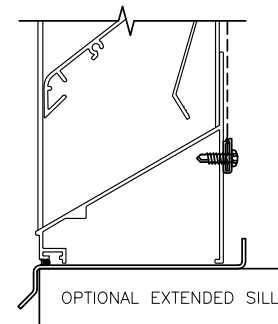
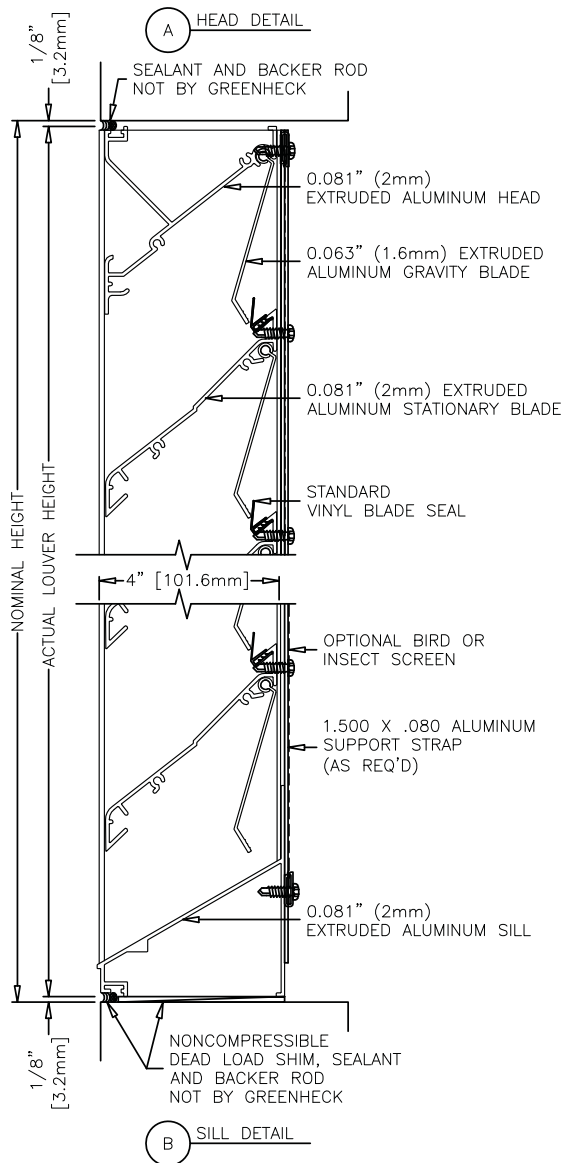

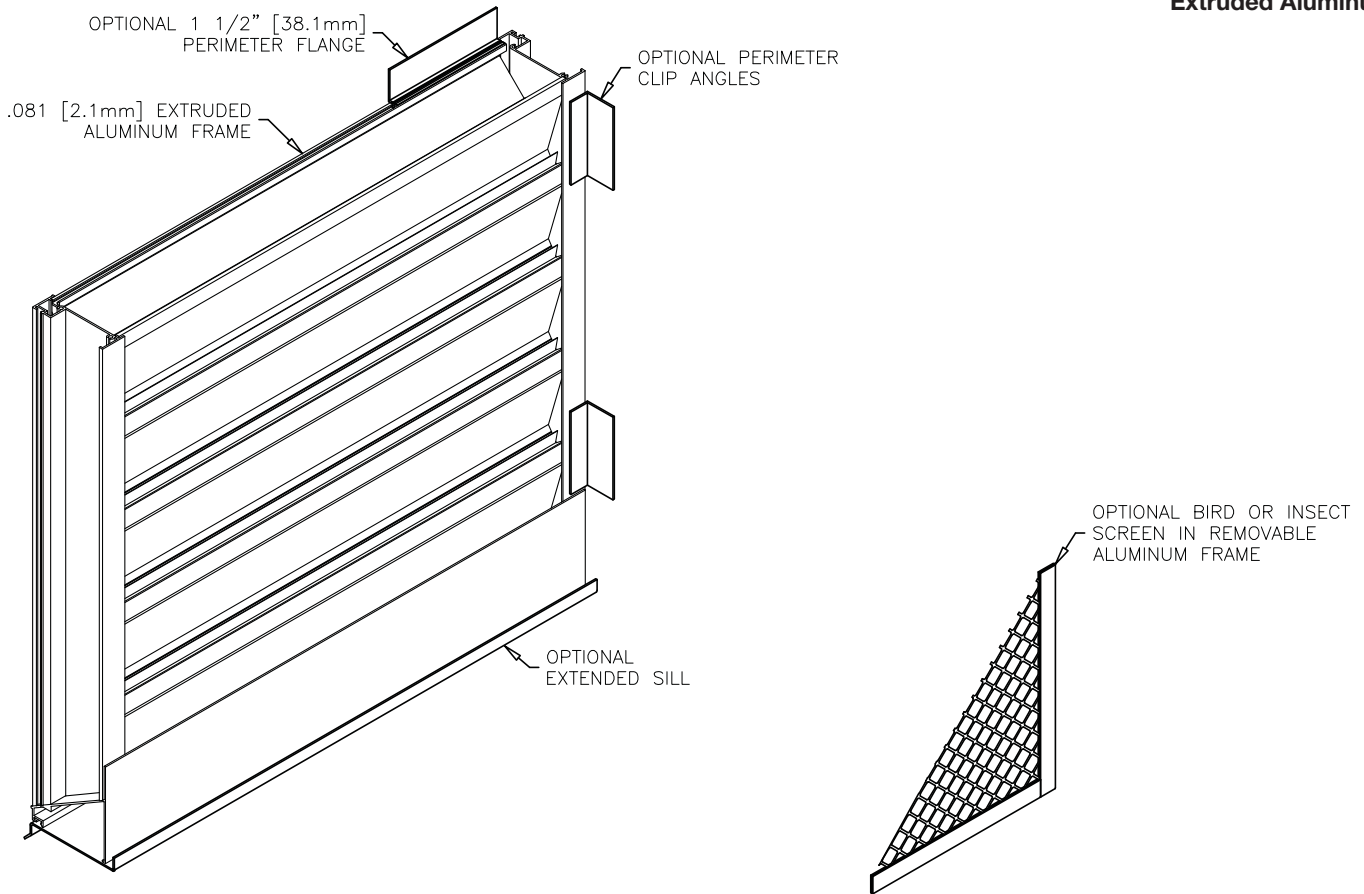

FINISHES

Finish Type	Description/Application	Color Selection	Standard Warranty (Aluminum)
2-coat 70% KYNAR 5000®/HYLAR 5000® AAMA 2605 – Dry film thickness 1.2 mil. (AKA: Duranar®, Fluoropon®, Trinar®, Fluoropolymer, Polyvinylidene Fluoride, PVDF2)	“Best.” The premier finish for extruded aluminum. Tough, long-lasting coating has superior color retention and abrasive properties. Resists chalking, fading, chemical abrasion and weathering.	Standard Colors: Any of the 24 standard colors shown can be furnished in 70% or 50% KYNAR 5000®/HYLAR 5000® or Baked Enamel. 2-Coat Mica: Greenheck offers 9 standard 2-coat Mica colors. Other colors are available. Consult Greenheck for possible extra cost when selecting non-standard colors or special finishes.	10 Years (Consult Greenheck for availability of extended warranty)
2-coat 50% KYNAR 5000®/HYLAR 5000® AAMA 2604 – Dry film thickness 1.2 mil. (AKA: Acroflur®, Acrynar®)	“Better.” Tough, long-lasting coating has excellent color retention and abrasive properties. Resists chalking, fading, chemical abrasion and weathering.		5 Years
Baked Enamel AAMA 2603 – Dry film thickness 0.8 mil. (AKA: Acrabond Plus®, Duracron®)	“Good.” Provides good adhesion and resistance to weathering, corrosion and chemical stain.		1 Year
Integral Color Anodize AA-M10C22A42 (>0.7 mil)	“Two-step” anodizing is produced by following the normal anodizing step with a second, colorfast process.	Medium or Dark Bronze	5 years
Clear Anodize 204 R-1 AA-M10C22A31 (0.4-0.7 mil)	Clear, colorless and hard oxide aluminum coating that resists weathering and chemical attack.	Clear	1 Year
Industrial coatings	Greenheck offers a number of industrial coatings such as Hi-Pro Polyester, Epoxy, and Permatector®. Consult a Greenheck Product Specialist for complete color and application information.		Consult Greenheck
Mill	Materials may be supplied in natural aluminum or galvanized steel finish when normal weathering is acceptable and there is no concern for color or color change.		n/a

Finishes meet or exceed AAMA 2605, AAMA 2604, and AAMA 2603 requirements. Please consult www.greenheck.com for complete information on standard and extended paint warranties. Paint finish warranties are not applicable to steel products.

