

Application and Design

Model HPR-120 is a heavy duty pressure relief damper with double flanged channel frame and single thickness blades. It is designed to protect HVAC systems and industrial processes by relieving air pressure. External heavy duty linkage, ball bearings, blade counterbalance and adjustable pressure setting weights are standard.

Ratings (See page 2 for specific limitations)

- Pressure Relief:** 0.1 in. wg (25 Pa) minimum
 2.0 in. wg (498 Pa) maximum
- Back Pressure:** 5.0 - 8.5 in. wg (1245 - 2117 Pa)
- Velocity:** 3900 - 5150 fpm (19.8 - 26.2 m/s)
- Temperature:** Minimum: -20°F (-29°C)
 Maximum with seals: 180°F (82°C)
 Maximum without seals: 250°F (121°C)
 Consult factory for temp. above 250°F (121°C)

Standard Construction (See page 3 for options)

- Frame:** 8 in. x 2 in. x 14 ga. (203mm x 51mm x 2mm) galvanized steel channel.
- Blades:** 2V type - 16 ga. (1.5mm) galvanized steel, eccentrically pivoted, 7 in. (178mm) max. spacing.
- Blade Seals:** Vinyl.
- Axles:** Plated steel 1/2 in. (13mm) dia.
- Linkage:** External heavy duty type with galvanized steel clevis arms and plated steel tie bars & pivot pins with nylon pivot bearings.
- Bearings:** Galvanized steel ball press fit into frame.
- Pressure Set:** Adjustable arms and weights.
- Finish:** Mill galvanized.

Size Limitations:

- Maximum Single Section Size: 48 in. W x 96 in. H
 (1219mm W x 2438mm H)
- Maximum Double Section Size: 96 in. W x 96 in. H
 (2438mm W x 2438mm H)
- Minimum Size: Single blade
 6 in. W x 6 in. H
 (152mm W x 152mm H)

Optional Features:

- Frame depth 8 in. - 12 in. (203mm - 305mm)
- Flange width 1 1/2 in. - 4 in. (38mm - 102mm)
- 304 stainless steel blade and frame
- 304 stainless steel axle
- No blade seal
- Bolt holes in flanges
- Stainless steel linkage
- Hi Pro Polyester paint finish

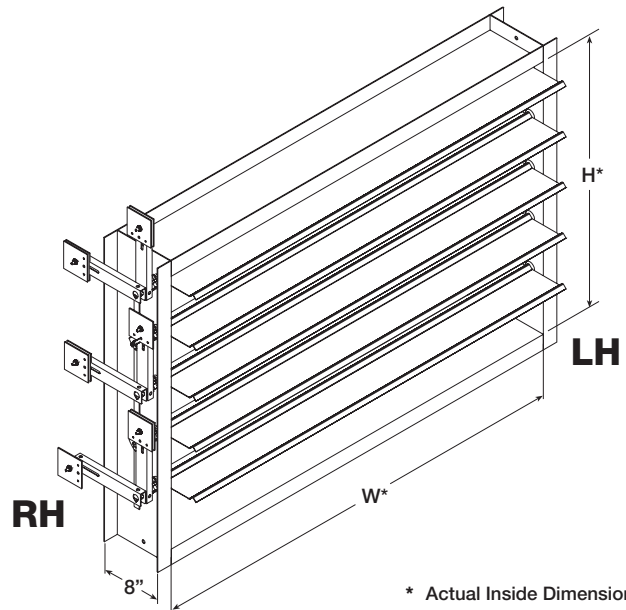

- * Actual Inside Dimension.
- ** The W dimension is ALWAYS parallel with the damper blade length.
- *** RH counterbalance and pressure setting are standard.
- **** Counterbalance and pressure setting weights extend beyond flanges in the open/closed positions.

Counterbalance & Pressure Setting Weight Dimensions

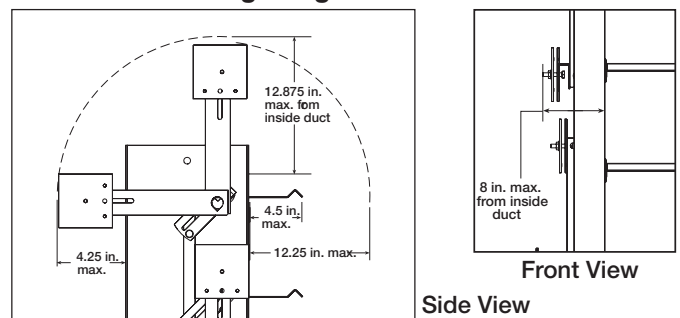

Advise flow direction, relief pressure, & counterbalance weight location when ordering

Back Pressure Limitations

The chart at the right shows conservative pressure limitations based on a maximum blade deflection of $w/360$.

Temperature Limitations

- Vinyl blade seals: -20°F to 180°F
 (-29°C to 82°C)
- No seals: -20°F to 250°F
 (-29°C to 121°C)

Velocity Limitations

The chart at far right shows conservative velocity limitations based on damper size.

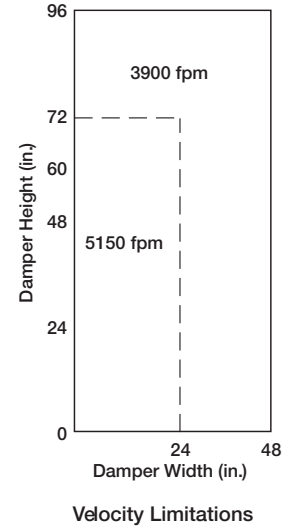
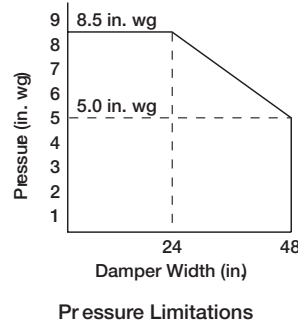

Pressure Relief/Leakage Data

This pressure drop data was conducted in accordance with AMCA Standard 500-D using the configuration shown. All data has been corrected to represent standard air at a density of 0.075 lb/cu.ft. (1.2 kg/m³). (The HB-120 data was included as a reference.)

Pressure Relief/Leakage
24 in. x 24 in. (610mm x 610mm) Damper

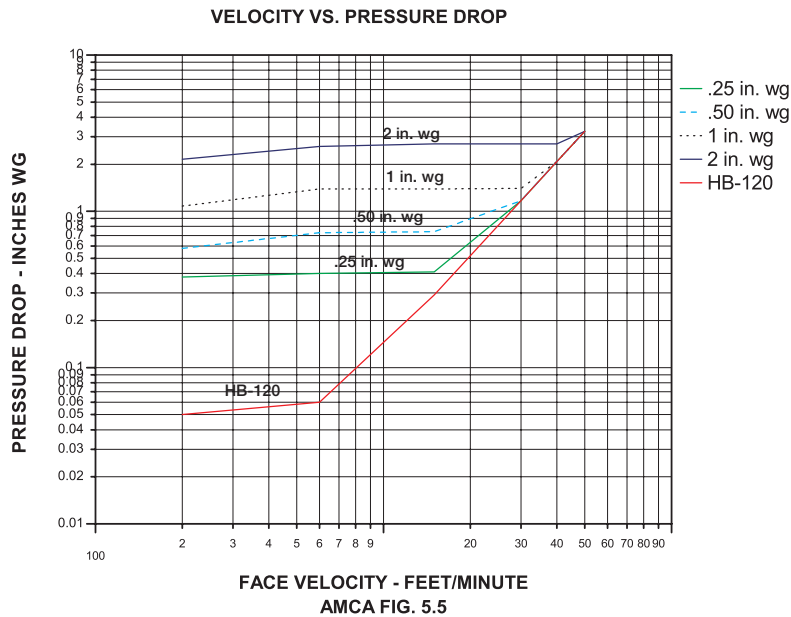

AMCA Test Figure

Figure 5.5 illustrates a plenum mounted damper. This configuration has high pressure drop because of entrance and exit losses due to the sudden changes of area in the system.

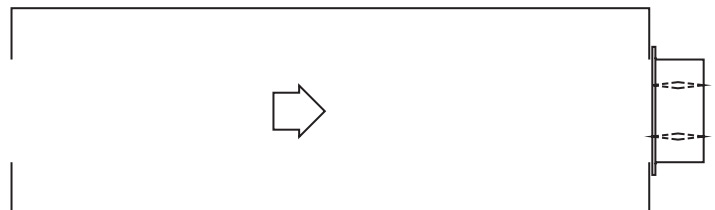

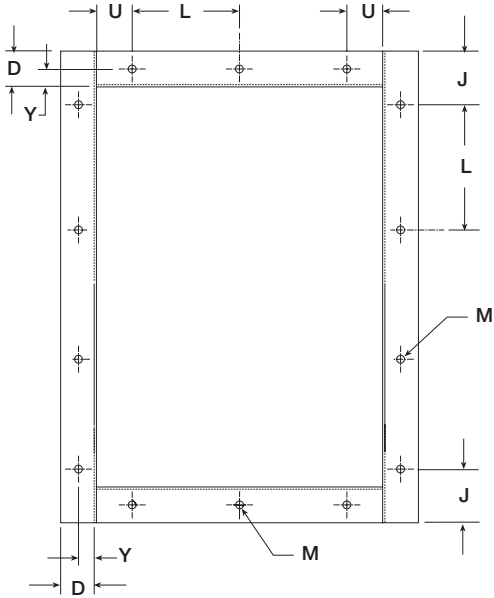

Bolt Holes are available as an option. Greenheck's standard pattern is 7/16 in. diameter holes (M dimension) spaced 6 in. on center (L dimension). Also, available is custom bolt hole pattern within the limitations of the chart below.

Bolt Hole Limitations

Dim.	Standard	(Min./Max.)	Description
J		(D/2 min.)	First/Last Space in Jamb
F		(1 min.)	No. of Holes in Jamb
L	6 in. (152mm)	2 in. /12 in. (51mm/305mm)	Hole Spacing
M	7/16 in.	1/4 in. / 11/16 in. (6mm/17mm)	Mounting Hole Diameter
U		3/4 in. min. (19mm)	First/Last Space in Head/Sill
V		1 min. (25mm)	No. of Holes in Head/Sill
Y	D/2 in.	3/4 in./D-3/4 in. (19mm/D -19mm)	Centerline of bolt hole from inside edge of frame

Multiple Section Assembly

Damper sizes larger than 48 in. x 96 in. (1219mm x 2438mm) and less than 96 in. x 96 in. (2438mm x 2438mm) will be supplied in one frame with two sets of blades separated by a mullion as shown below. Counterbalance and pressure set weights supplied on right hand and left hand side. For sizes larger than 96 in. x 96 in. (2438mm x 2438mm) consult factory.

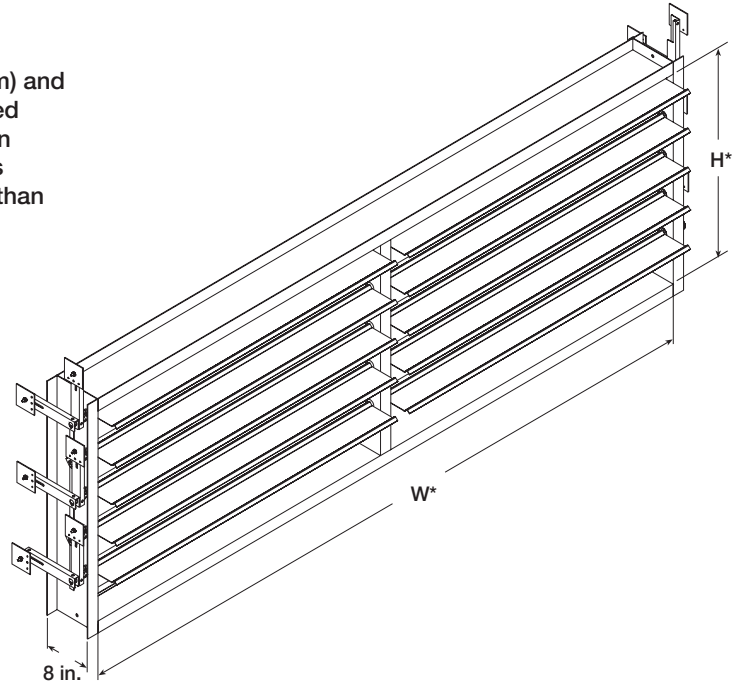

Specifications

Industrial grade pressure relief dampers meeting the following specifications shall be furnished and installed where shown on plans and/or as described in schedules.

Dampers shall consist of: a 14 ga. (2mm) galvanized steel channel frame with 8 in. (203mm) minimum depth and 2 in. (51mm) flanges; double V type blades fabricated from 16 ga. (1.5mm) galvanized steel; 1/2 in. (13mm) dia. plated steel axles turning in galvanized steel ball bearings press fit into frame; and external (out of the airstream) heavy duty linkage with counterbalance and pressure set weights.

Damper manufacturer's printed application and performance data including pressure, velocity and temperature limitations shall be submitted for approval showing damper suitable for back pressures to 8.5 in. wg (2117 Pa), relief pressures to 2 in. wg (498 Pa), velocities to 5150 fpm (26.2 m/s), and temperatures to 250°F (121°C).

Testing and ratings to be in accordance with AMCA Standard 500-D.

Basis of design is Greenheck model HPR-120.